

Assembly Instructions

for Müller Light and Ventilation Ridge „Deluxe Agrar XL“

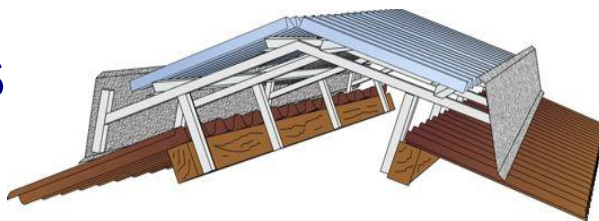

DIN EN 1090

Important notes!

Bearing loads of Müller Light and Ventilation Ridge must be considered in the design of the removed purlins!

Preamble

The correct and technically perfect use of the products and compliance with the applicable accident prevention regulations during installation are not subject to our control.

In conformity with these assembly instructions a smooth and quick assembly succeeds.

We hope you will enjoy the **Mueller Light and Ventilation Ridge „Deluxe Agrar XL“** now and as well in the future.

Storage *(Please pay attention to the instructions immediately after delivery!)*

Upon receipt of the construction kit, the stacked, bare aluminium profiles (wind deflectors, purlins and frame) should be immediately separated. Moisture between the stacked sections and profiles due to rain, humidity or condensation could otherwise cause an unsightly discolouration (gray black) of the parts.

Never expose the skylight panels / hoods in the stack to direct sunlight or excessive heat – heat accumulation – burning glass effect. This may lead to deformations!

For intermediate storage or provision on the site, all parts should be covered with an opaque material to protect against moisture as well as against wind and storm. Packaging ex factory serves as protection during the transport and is not suitable for storage.

The storage for an extended period should be carried out "under roof".

Assembly

1. Fasten the first and last pair of aluminium supports with either two screws (MLL 60 to 250) or with three screws (MLL 300 to 400) with the purlins so that the supports protrude 255 mm beyond the existing roof cover (see picture). Use for timber purlins the stainless steel drill screws 6,5 x 65 mm and for steel purlins the stainless steel drill screws SX 5 (5,5 x 33 mm). If your roofing has a profile height of more than 7 cm or ridge purlins less than 14 cm in height, please consult with us prior to installation.

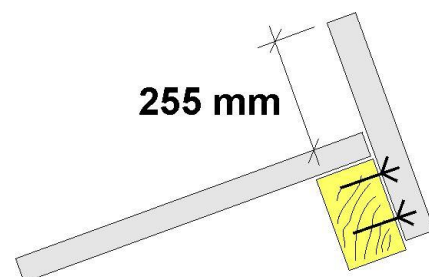

2. Stretch a cord and align the other supports and also fasten them with two resp. three drill screws. The support spacing for the »Deluxe Agrar Type Hall« **MLL 60 to 200 is 1440 mm** (center to center supports) or **960 mm for the MLL 225 to 400**. The spacing is necessary to be observed.

If you want a small lateral protrusion of the light dome, the support spacing of the first and last section has to be reduced accordingly (max. 100 mm protrusion).

3. Now position the welded aluminum frame, also aligned them by means of a cord and attach to each aluminium support with two stainless steel drill screws SX5 .

4. Now the diagonal support is attached and fixed to both the support and the frame with two SX5 drill screws (see sketch).

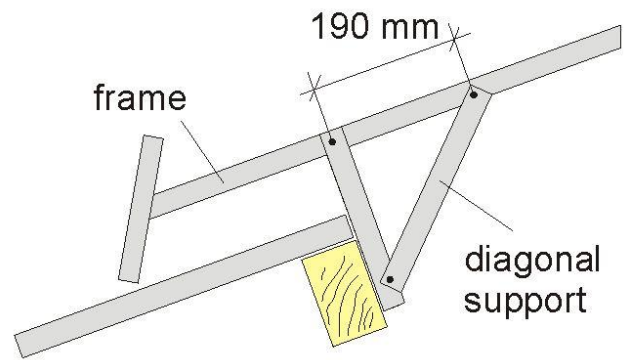

5. Put Al-Z-purlins on the frame, according to sketch, and fix each support with SX5 drill screws. The overlap of the purlins is 120 mm and is located exactly on a frame. Pay attention to the correct size of ridge and the number of the row of purlins per side.

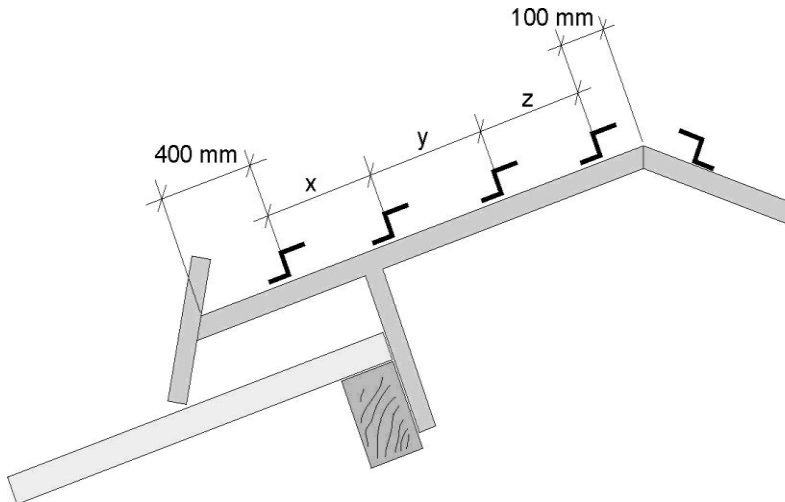

Deluxe Agrar XL 60 to 160
two z-purlin at each side

Deluxe Agrar XL 180 to 300
three z-purlin at each side (*distance x = y*)

Deluxe Agrar XL 350 and 400
four z-purlin at each side (*distance x = y = z*)

6. The the skylight panels 15 mm from the ridgetop on the Al-Z-purlins. This results in an additional air gap of about 30 mm width. The hoods have a lateral overlap of 5 cm (see sketch). This results in a coverage width of 1040 mm per hood.

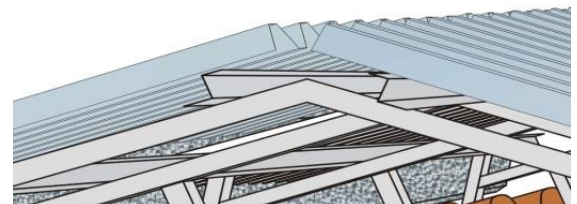

Place the hoods and attach them to all Z purlins in each second lower flange with SX5 stainless steel drill screws. Then the skylight panels are fixed on all purlins to every 2nd chord with SX5 stainless steel self-drilling screws. **Never** mount the skylight panels the other way round because of the coextrusion!

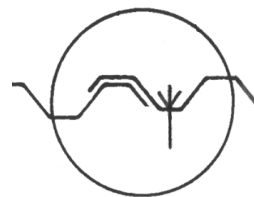

7. Put Al trim corners on the holding device of the wind deflectors, then align the Al wind deflectors (reinforcing bead down) and attach each with 3 SX5 drill screws per bracket. Attach the upper drill screw at a level, so that the trim corner is mounted simultaneously. The overlap of the trim corners and the wind deflectors is 120 mm, alike the purlins, and is located exactly on a holding device of the wind deflector. Finally, the wind deflectors are each attached with a screw exactly between the frames at the trim corner in order to avoid noise due to the wind.

